

Operation & Maintenance Manual

Idesign Heated Drop-in Displays

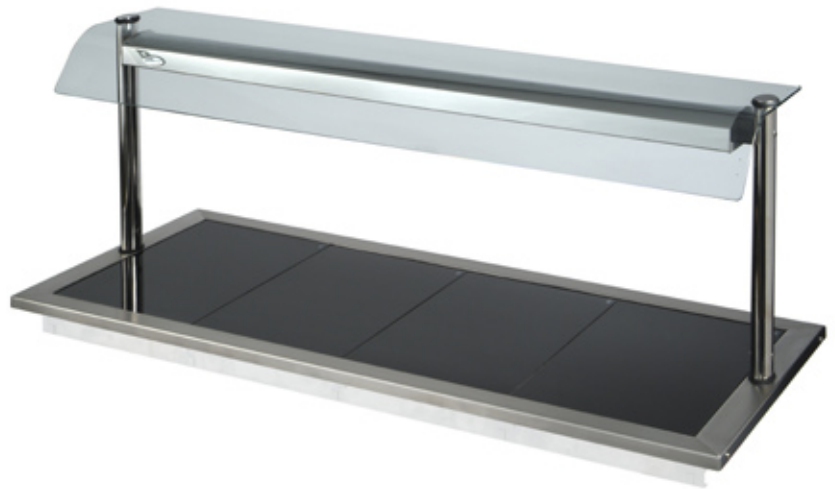

IMPORTANT

Counterline Ltd cannot be held responsible for any accidents or injuries sustained through misuse or improper operation / maintenance of its products. Please follow our guidelines set out within this handbook for safe working practice. At the design stage, please ensure that the counter understructure can take the weight of the display(s), and that adequate provision has been made for lifting and positioning the display, to avoid risk of damage or injury.

SAFETY INFORMATION

It is essential that this Idesign unit is provided with an electrical supply by a qualified electrician and installed by a competent person.

The presence of liquids on the display and risk of spillage must be taken into account in designing the electrical installation around the unit. For additional safety we strongly recommend the fitting of a 30ma trip RCD protection device to the electrical supply.

Idesign display units are heavy. We strongly recommend the use of mechanical lifting equipment when handling the units and positioning them in counters. If no such lifting equipment is available then sufficient personnel must be available to handle each unit without contravening Company or site Health and Safety Policies.

Before commencing any cleaning or maintenance operation the Idesign unit must be isolated from the mains supply by either removing the supply plug from its socket or switching off at the local isolator.

NB: Switching off using the power switch on the control panel does not fully isolate the unit. These instructions must be implemented in conjunction with your own Company's Health and Safety instructions.

The following denotes the correct electrical supply required, dependant on unit size:

Ceran Hotplates		
2/1	1.2 kw	13 amp supply
3/1	1.8 kw	13 amp supply
4/1	2.4 kw	13 amp supply
5/1	3.0 kw	13 amp supply
6/1	3.6 kw	16 amp hard wired supply

Bain Marie Dry Well		
2/1	1.6 kw	13 amp supply
3/1	2.4 kw	13 amp supply
4/1	3.2 kw	16 amp hard wired supply
5/1	4.0 kw	20 amp hard wired supply
6/1	4.8 kw	20 amp hard wired supply

Bain Marie Wet Well		
2/1	2.1 kw	13 amp supply
3/1	3.2 kw	16 amp hard wired supply
4/1	4.2 kw	20 amp hard wired supply
5/1	5.3 kw	32 amp hard wired supply
6/1	6.3 kw	32 amp hard wired supply

WARRANTY

All Counterline products are guaranteed against faulty materials and workmanship for 12 months from the date of invoice provided that they have been installed, operated, cleaned and maintained in accordance with these instructions.

This guarantee specifically excludes damage caused by misuse, scratched or broken glass, quartz heat lights, fluorescent lights and electronic starters.



***BEFORE CARRYING OUT ANY MAINTENANCE
OR CLEANING OPERATIONS SET OUT IN THIS
MANUAL, PLEASE ENSURE THAT THE
ELECTRICAL POWER SUPPLY IS ISOLATED
AND SWITCHED OFF AT THE MAINS.***

Index

1. OPERATION

- 1.0 Introduction
- 1.1 Switching Your Idesign Heated Display Unit On
- 1.2 Loading With Food
- 1.3 Quartz Heat Lights
- 1.4 Heated Ceramic Glass Hotplate Operation
- 1.5 Dry Heat Bain Marie's
- 1.6 Heated Deli
- 1.7 Dry Heat Soup Bain Marie
- 1.8 Wet Well Bain Marie Operation
- 1.9 Hot Cupboards
- 1.10 Heated Plate Dispensers
- 1.11 Replacement Of Sneeze Screen Glass
- 1.12 Floor Mounted Power Boards

2. CLEANING

- 2.0 Cleaning Safety Note
- 2.1 Quartz Light Cleaning
- 2.2 Stainless Steel Cleaning
- 2.3 Ceramic Glass Hotplate Cleaning
- 2.4 Dry Heat Bain Marie Cleaning
- 2.5 Heated Deli Cleaning
- 2.6 Hot Cupboard Cleaning
- 2.7 Wet Well Bain Marie Cleaning
- 2.8 Heated Plate Dispenser Cleaning
- 2.9 Cleaning Glass

3. TROUBLE-SHOOTING

- 3.0 Self Help Guide

OPERATION

These instructions will guide you through the testing, operation, cleaning and maintenance of your Idesign heated display.

Idesign countertop and drop in food display units are designed for simple operation and will give many years of trouble free service provided that these instructions are adhered to.

It is essential that you read the instructions carefully and follow all of the cleaning and maintenance instructions. Failure to do so can result in premature failure that will not be covered by warranty.

1.1 Switching Your Heated Display Unit On

Idesign Gantry Control Panel

Check that your Idesign unit has been connected to a mains supply by your installer, and that this supply is live. You can now operate both the lower heat and upper heat controls.

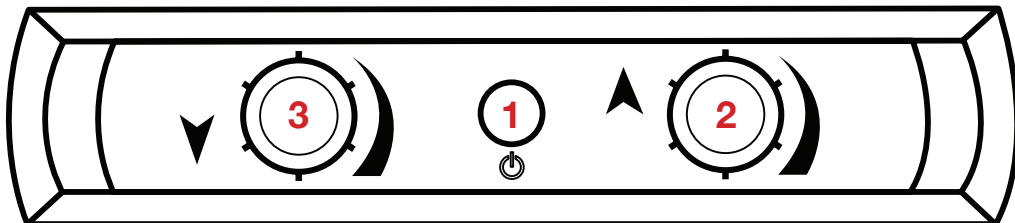

1	Centre button = ON/OFF switch. Illuminates when on. Flashes slowly when off. Flashes rapidly on overheat/ cutout. When cooled after approximately 15 minutes, switch ON/ OFF switch back on again . If rapid flashing continues seek advice.
2	Right hand control = upper heat. Turn clockwise to increase illumination and heat settings.
3	Left hand control = Base heat. Turn clockwise to increase base temperature.

Operating Conditions

It is recommended that the display is situated in a draught free environment with a surrounding ambient temperature of no less than 16 deg C.

Where ambient temperatures are below 16 deg C or draughty conditions exist, the display will not maintain food temperatures at required levels.

Turn your display on full for at least 30 minutes before loading with food, and then adjust to suit product type. Idesign heated display units are designed to merchandise food that is already at a temperature of around 70 deg C.

It is essential that all food has been heated to at least this temperature before being placed in the display. They are not designed to heat food from ambient temperature.

1.2 Loading With Food

The quartz heat lights fitted over most heated displays are designed to maintain the surface temperature of the food where it is exposed to air. They are controlled by an electronic dimmer located at the right hand side of the control panel. This provides adjustment of the heat output over a wide range.

The optimum setting will be found by experience; too low a setting will not maintain the temperature of the food, too high will result in drying out. If any of the lights fails to illuminate refer to the next section.



**THIS AREA WILL
PRODUCE HEAT, AVOID
TOUCHING WHILE THE
UNIT IS TURNED ON, AND
FOR 20 MINUTES AFTER**

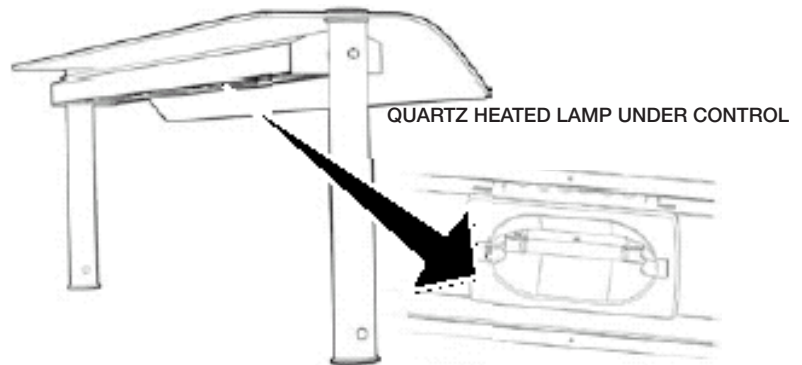

1.3 Quartz Heat Lights

The lights fitted are 300-watt halogen infrared heat lights and a competent maintenance engineer (who need not be a qualified electrician) can change them. These lights simply clip into a ceramic holder.

Before changing a quartz light the unit must be isolated from the supply.

It is most important not to touch the surface of the lights, they come wrapped in tissue paper and this must not be removed until the bulbs are safely clipped into position. It must be removed before the lights are turned back on. If the surface of the quartz light is accidentally touched, it must be cleaned with methylated spirits on a pad of tissue. In all cases when a quartz light is changed it is recommended that the reflector is cleaned with methylated spirits on a pad of tissue to remove any burnt on grease. This is done most easily after removing the old light and before inserting the new one.

1.4 Heated Ceramic Glass Hotplate

The temperature of Idesign hotplates is controlled by a rotary control located on the left-hand side of the gantry controller. See control diagrams in 1.1.

The controls are turned clockwise from the off position by 180 degrees and the hotplate will reach operating temperature (100-110 deg C) in 20 to 30 minutes. The setting may be adjusted up or down to adjust the food display temperature.

1.5 Dry Heat Bain Marie's

The bain marie will reach operating temperature in about 30 to 40 minutes when set at full. The setting may be adjusted up or down to alter the food display temperature.

Satisfactory temperatures will only be obtained if all apertures are filled with containers or fitted with lids. The bain marie is not designed to heat food.

All food placed in containers for service must be already at or above the desired service temperature. Each Idesign bain marie is supplied with element cover plates, which spread the heat from the elements evenly over the bases of the containers. These plates must be in position at all times when the unit is in use; some discolouration due to the high temperatures achieved is normal.

1.6 Heated Deli

The temperature of the Idesign heated deli is controlled by two rotary controls which indicate upper heat and lower heat. These two controls alter the heat output from the quartz lights above the upper and lower display areas respectively. They provide steplessly variable adjustment of the heat output over a wide range. The optimum settings will be found by experience; too low a setting will not maintain the temperature of the food, too high will result in drying out.

1.7 Dry Heat Soup Bain Marie

The temperature of the Idesign soup bain marie is controlled by a rotary thermostat located on the main control panel and labelled heat.

The thermostat is turned from the off position clockwise through 180 degrees and the Bain Marie will reach operating temperature in about 30 to 40 minutes. The setting may be adjusted up or down to alter the soup temperature.

Satisfactory temperatures will only be obtained if the aperture is fitted with either one 2/3 or two 1/3 containers or fitted with lids.

1.8 Wet Well Bain Marie's

Filling with water and switching on

First check that the lever valve on the main drain is in the closed position with the operating lever horizontal or the gate valve (if fitted) fully turned clockwise.

Ensure that the control knobs on both control panels are turned fully anti-clockwise to the off position.

Turn on the water feed tap, which should be located in a service cupboard under the bain-marie.

Allow the unit to fill with water up to the marked level (about 25mm above the element cover plates) then turn the water feed off.

Ensure that all apertures in the bain marie are filled with empty containers or covered with lids.

The unit will take around 45 minutes to reach operating temperature at which point the apertures can be filled with containers containing pre heated food.

The settings of both rotary controls can then be adjusted to give the required food temperature.

During the service period the water level should be checked every thirty minutes or so by removing a container and additional water added if necessary.

Draining the wet well bain marie

Carry out this operation with the control knobs turned fully anti-clockwise to the off position. If the bain marie is connected to a plumbed drain then the tank is drained simply by turning the handle on the drain valve under the tank to the vertical position, or by turning the handle of the gate valve if fitted fully anti-clockwise.

If the bain marie is not connected to a plumbed drain then the tank must be drained into a bucket or similar container positioned under the outlet from the waste valve.

This manual draining should only be carried out after the water in the tank has been allowed to cool. Do not overfill the bucket or container and take care in handling the water to avoid spillage. Refer to company health and safety policy with reference to carrying unstable heavy loads.

1.9 Hot Cupboards

l design hot-cupboards are available as both mobile roll under units and also as slide-in units designed to be accommodated in a shop fitted carcass. Operation of both types is essentially the same.

Operation

The digital controller controls the circulating air temperature. It is pre set to an average air temperature of 75 degrees Centigrade. Normal operator control is by using the on/off switch marked power only. The hot-cupboard air temperature will now be displayed on the controller. The hot-cupboard will automatically reach operating temperature in 30 to 40 minutes and will maintain itself at that temperature until switched off. The digital controller is pre-set at the factory and can only be adjusted within predetermined limits.

Satisfactory temperatures will only be maintained if the doors are kept closed when access is not required. To assist cleaning and for service access to the fan and heater module, the doors and centre shelf are removable.

The doors are removed by reaching underneath the mid shelf of the hot-cupboard and lifting the front of the shelf by about 25mm, this will release the doors from their guide and enable them to be pulled outwards at the bottom. In this position the shelf can be released and the top guide rollers on the doors can be unhooked from the upper track. When the doors have been removed the centre shelf can be lifted upwards and outwards to clear the four supports allowing unrestricted access to the interior of the hot-cupboard. Periodic cleaning of the upper guide track is important to ensure free running of the rollers.

During re-assembly, care must be taken to ensure that the both the top door guide rollers engage correctly into the upper track and that the lower guide rollers engage the channel under the front edge of the mid shelf.

Instructions For Setting The Hot-cupboard Digital Controller

The digital controller will be pre set at the factory to give a food display temperature of 75 deg C in typical operating conditions. Under normal conditions the controller displays the actual temperature of the hot air around the food.

If you need to alter the pre set temperature proceed as follows:

1. To display the pre-set temperature, depress the set button.
2. When the button is released the unit will return to displaying the actual operating temperature after a short time.
3. To set a new temperature follow the instructions outlined below:

4. Depress the set button, whilst keeping this button depressed adjust the temperature to your new setting by pressing the up and down arrow buttons. The up button raises the air temperature; the down button lowers it. Once the required temperature has been set, release all buttons and the unit will return to displaying the operating temperature.

It is important that only small adjustments of say 1 or 2 deg C are made to the controller at any one time. The unit should then be allowed to operate for at least one normal working day and food core temperatures monitored before any further adjustments are made.

1.10 Heated Plate Dispensers

Switching On

Check that your Idesign plate dispenser unit has been connected to a mains supply by your installer (usually a 13 amp plug and socket within the counter body), and that this supply is live. The counter manufacturer will have provided you with an accessible switch that controls the supply of power to the socket.

Set this switch to the **ON** position

If any adjustments for plate weight or temperature are required, unplug the unit and allow it to cool first.

Operation

Temperature is pre-set by a control located on the upper surface of the base plate of the unit. This is visible as a small spindle with a screwdriver slot after removal of the stainless steel plate carrier disc, which lifts out. Any adjustments to the factory setting should be very small (1/10 of a turn) and the effect on plate temperature noted over a day or so before further changes are made. Turning the control clockwise raises the plate temperature, anti-clockwise lowers it.

Remember that the unit is primarily designed to maintain the temperature of pre heated plates during a service period, if it is filled with a stack of cold plates they will take at least an hour to heat up. If you have no other method of heating plates specifying the optional cover, which retains the heat, will speed up the heating operation.

Adjustment for Plate Weight

Adjustment to accommodate different weights of plate is effected by adding or carefully removing springs, which support the plate carrier. Springs must be removed or added symmetrically around the carrier otherwise it will not slide freely. The unit should be adjusted so that about four or five plates are above the rim at any time.

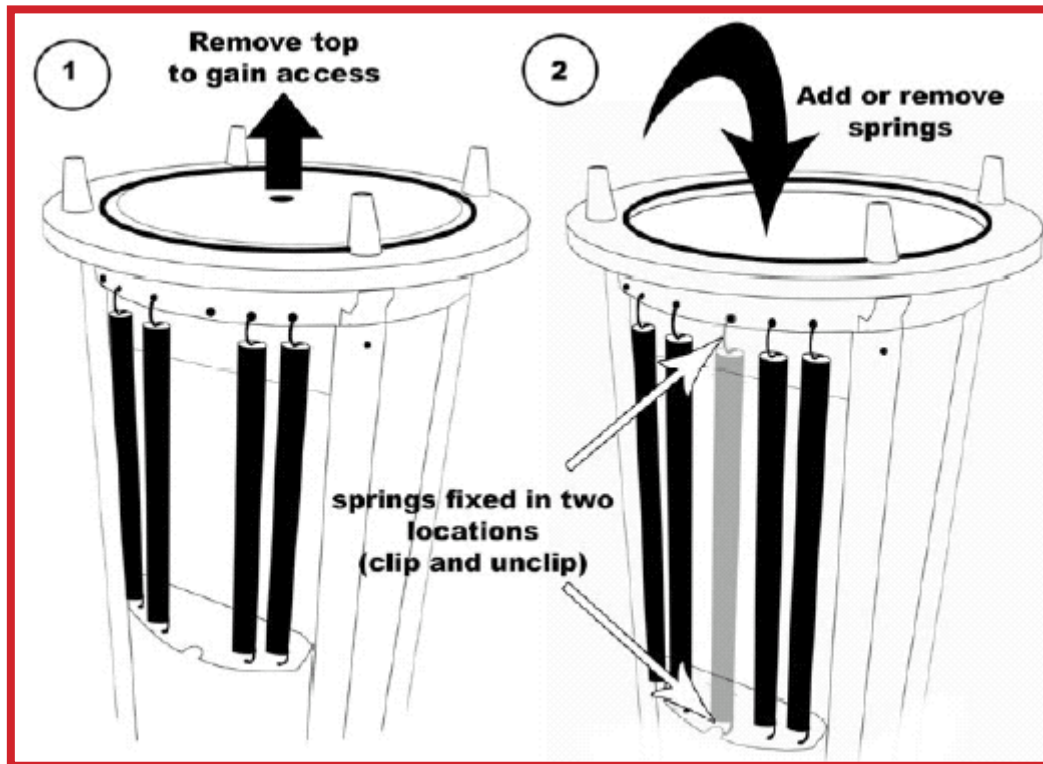

1.11 Replacement Of Sneeze Screen Glass If Fitted

Most Idesign units feature curved toughened glass sneeze screens mounted on top of two oval support posts. If this glass becomes chipped or scratched it must be replaced at the earliest possible opportunity as its resistance to breakage by impact or changes in temperature is considerably reduced.

Normally replacement glass can be shipped to you by overnight carrier and the operation to change the glass carried out by any competent maintenance technician or the company that initially supplied your Idesign unit.

The following operations must only be carried out by persons wearing safety goggles giving all round eye protection:

integrale[®]

1. Isolate the unit from the electrical power.
2. With an assistant to steady the glass, unscrew the two stainless steel allen screws, one in the top of each oval post using the key provided in the fitting kit.
3. Remove the screws, stainless steel ovals and the black plastic mouldings.
4. With an assistant lift both ends of the glass slowly clear of the unit and place it upside down on a flat surface protected by a cloth.
5. Remove the damaged glass from the area and lay the new piece of glass, unwrapped, upside down on the cloth.
6. Again using an assistant and with one of you holding each end of the glass, lower the new glass into position onto the top of the oval posts (ensuring that the lower black plastic moulding is still in place)
7. Ensure that the holes in the glass line up with the threaded holes in the top of the posts.
8. Replace the upper black plastic moulding, stainless steel ovals and screws.

9. Tighten the screws using the key provided in the fitting kit. Do not over tighten as this may cause breakage of the glass.

**P.P.E should be worn when handling glass i.e eye protection and gloves.
If it is necessary to change the glass on a deli please contact our service department for help.**

da vinci[®]

1. Isolate the unit from the electrical power.
2. Prise off top cover off both gantry posts.
3. With an assistant, unscrew both stainless steel allen screws, one in the top in each oval post, using the allen key provided in the fitting kit.
4. Remove screws and black plastic mouldings.
5. With an assistant lift both ends of the glass slowly clear of the unit and place it upside down on a flat surface protected by a cloth.
6. Remove the damaged glass from the area and lay the new piece of glass, unwrapped, upside down on the cloth.
7. Again using an assistant and with one of you holding each end of the glass, lower the new glass into position onto the top of the oval posts (ensuring that the lower black plastic moulding is still in place)
8. Ensure that the holes in the glass line up with the threaded holes in the top of the posts.
9. Replace the upper black plastic moulding, stainless steel ovals and screws.
10. Tighten the screws using the key provided in the fitting kit. Do not over tighten as this may cause breakage of the glass.

**P.P.E should be worn when handling glass i.e eye protection and gloves.
If it is necessary to change the glass on a deli please contact our service department for help.**

manhattan[®]

1. Isolate the unit from the electrical power.
2. With an assistant to steady the glass, unscrew the four off pig-nose fixings at either end of the glass using the pig-nose spanner provided in the fixing kit.
3. Remove screws and black plastic mouldings.
4. With an assistant lift both ends of the glass slowly clear of the unit and place it upside down on a flat surface protected by a cloth.
5. Again using an assistant, and with one of you holding each end of the glass, lower the new glass into position and refix with the four-off pig-nose fixings.
6. Tighten the screws using the key provided in the fitting kit. Do not over tighten as this may cause breakage of the glass.

**P.P.E should be worn when handling glass i.e eye protection and gloves.
If it is necessary to change the glass on a deli please contact our service department for help.**

1.12 Floor Mounted Power boards

Large Floor Mounted Power Board (4kw to 7kw loading)

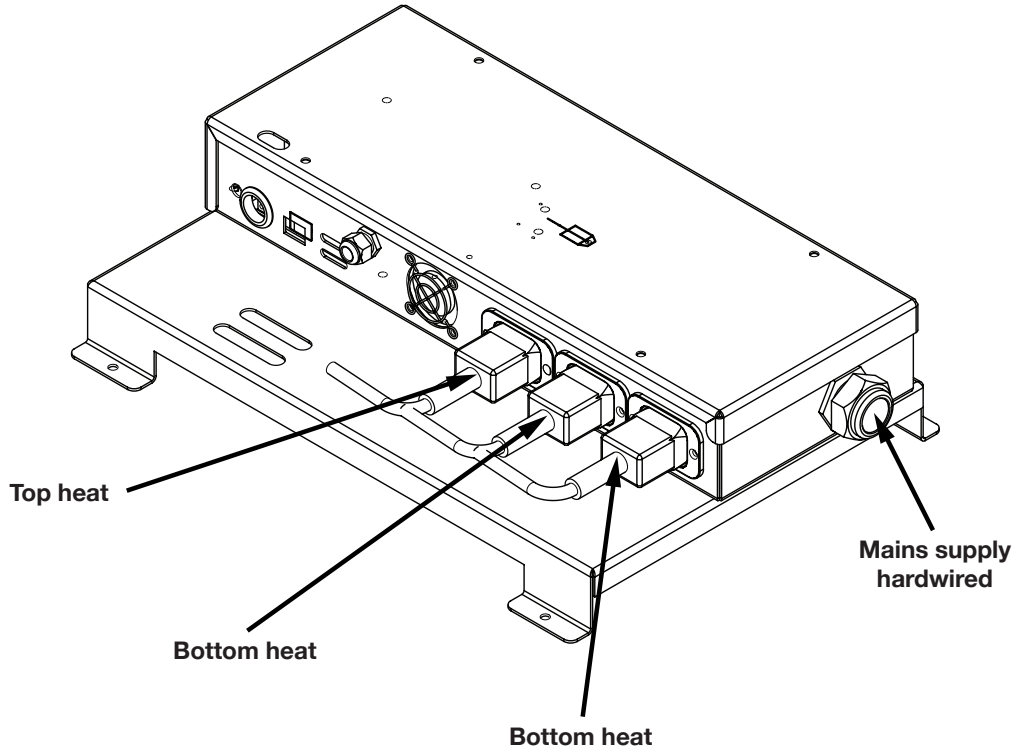

Small Floor Mounted Power Board (3kw loading)

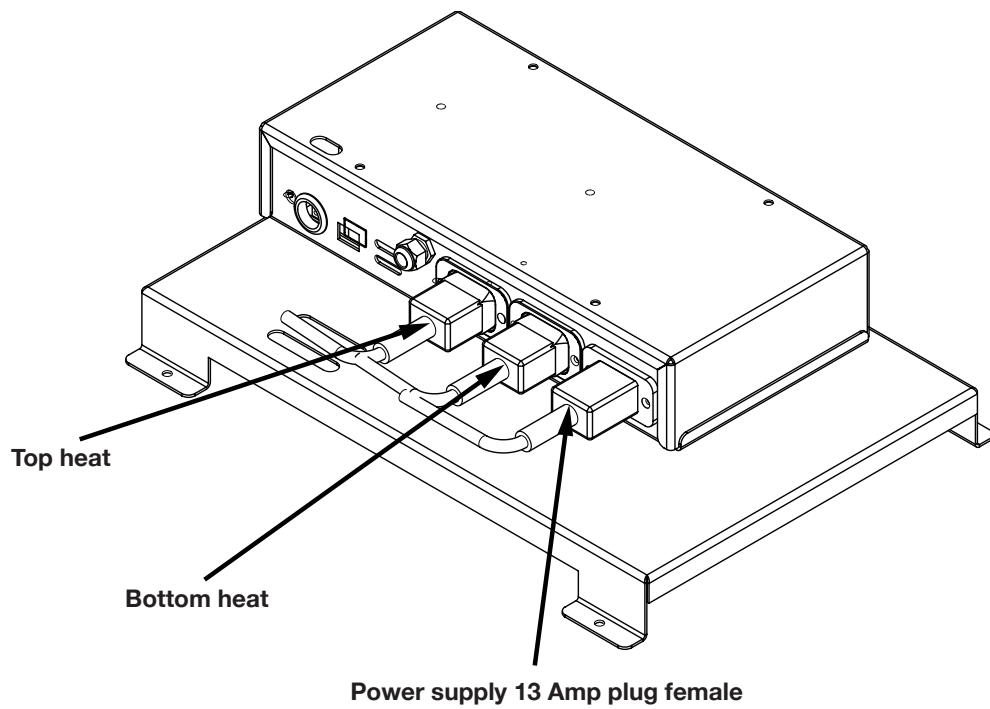

CLEANING

2.0 Cleaning Safety Note

Before commencing any cleaning operation the Idesign unit must be isolated from the mains supply by either removing the supply plug from its socket or switching off at the local isolator.

NB: Switching off using the power switch on the control panel does not fully isolate the unit. Under no circumstances must a pressure washer or hose pipe be used in the vicinity of this unit.

2.1 Quartz Light Cleaning

The service life of the quartz heat lights will be extended if they are carefully cleaned when cold once a week using a pad of tissue slightly moistened with methylated spirits. Nothing else should be used. At the same time the reflectors should be wiped clean with a similar pad. The fingers should never be allowed to come into contact with the lights.



ENSURE THAT YOUR DESIGN UNIT IS SWITCHED OFF AND THAT ALL AREAS OF THE UNIT INCLUDING THE QUARTZ HEATED LIGHTS HAVE COOLED SUFFICIENTLY TO CLEAN.

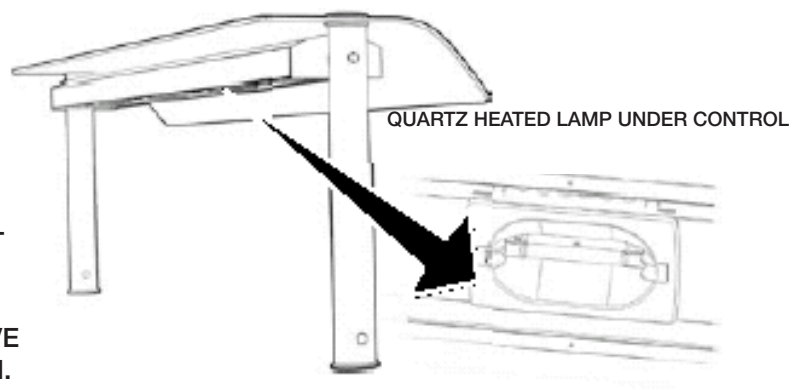

2.2 Stainless Steel Cleaning

Stainless steel should be cleaned daily using a suitable proprietary stainless steel polish applied in accordance with the manufacturer's instructions.

A list of recommended cleaning products is available from our service department.

Do not use harsh abrasives or cleaning pads such as Scotchbrite

2.3 Ceramic Glass Hotplate Cleaning

Ceramic glass hotplates should be cleaned using a proprietary glass/ceramic hotplate cleaner, normally available from your installer or a domestic kitchen appliance retailer. Wire wool, Scotchbrite and similar abrasives must not be used. The hotplates should be cleaned after every food service period, otherwise deposits of burnt on food waste may build up and damage may be caused in attempting to remove them. Cleaning should be carried out when the hotplate is still warm after use.

2.4 Dry Heat Bain Marie Cleaning

The inside of the Bain-Marie tank should be cleaned with a damp (but not wet) Scotchbrite pad and a little detergent, preferably whilst it is still warm after each service period.

It should then be wiped dry with a clean cloth.

The element covers can either be cleaned in the same way or passed through a dishwasher. When cleaning the Bain-Marie great care must be taken not to bend the rod elements, as this will ultimately cause electrical failure.

2.5 Heated Deli Cleaning

The stainless steel display deck and overself should be cleaned after every service period, otherwise deposits of burnt on food waste may build up and damage may be caused in attempting to remove them. This should be carried out when the unit is still warm after use.

2.6 Hot Cupboards Cleaning

The interior of the hot-cupboard should be cleaned with a damp (but not wet) Scotchbrite pad and a little detergent, preferably whilst it is still warm after use. (It should then be wiped dry with a clean cloth).

On fan assisted units care must be taken to ensure that food debris is not pushed through the air circulation grilles. (It should then be wiped dry with a clean cloth).

2.7 Wet Well Bain Marie Cleaning

The element covers should first be removed and may be cleaned in a sink or dishwasher. The main tank should be cleaned with a Scotchbrite pad and a little detergent, preferably whilst it is still warm after each service period. It should then be wiped dry with a clean cloth.

When cleaning the bain marie great care must be taken not to bend the rod elements, as this will ultimately cause electrical failure or water leakage.

After cleaning the element covers must be replaced before refilling for the next service period.

2.8 Heated Plate Dispensers Cleaning

In normal use the unit should only require cleaning of the plate support disc and the upper rim using a damp cloth and a little detergent. From time to time the stainless steel should be cleaned daily using a proprietary stainless steel polish applied in accordance with the manufacturers instructions. If the unit is used in a manner where food is served onto the top plate in the stack (e.g: a carvery, more thorough cleaning of the inside of the unit will be required, probably on a weekly basis).

It should be lifted from the counter, unplugged and thoroughly wiped out paying particular attention to the ball bearings and their four guide channels, which support the main plate carrier assembly.

2.9 Cleaning Glass

Glass shelves and sneeze screens should be cleaned daily or as required using a proprietary glass cleaner and clean cloth. Care should be taken to select a cleaner with minimum odour to avoid food tainting.

Your unit may be provided with the optional full height curved glass sneeze screen and fully glazed ends. The ends are located into black plastic guide channels and fixed in place with special flush stainless steel screws. Normally the ends can be cleaned in situ, but occasionally they should be removed to allow for more thorough cleaning. The fixing screws can be removed and replaced with the special tool provided in the fixing kit. When removing them take note of the position of the spacing washers and replace them in exactly the same order. When replaced, the fixing screws should not be over tightened or the glass may be damaged.

The front glass is supported along its lower edge in a full-length hinge, so that the glass can be opened forwards towards the customer side for access to clean its inner face. To open the glass, stand in front of the counter, take hold of both ends of the glass at the top and pull it upwards and towards you.

The glass has a restraining device built into its hinge. This is just a restraining device and is not designed to support the full weight of the glass. When cleaning ensure that you hold the glass with one hand and refrain from putting any additional weight on the glass or hinge.

After cleaning, the glass is returned to its normal position.

TILTING THE GLASS FORWARD

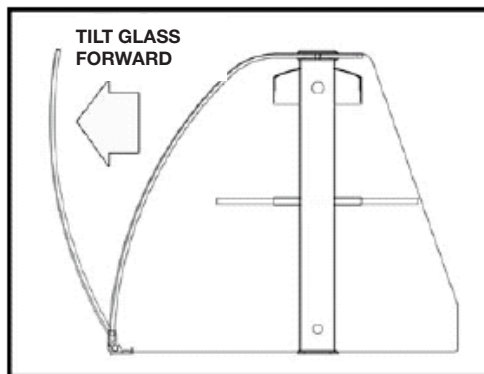

REMOVING THE GLASS ENDS

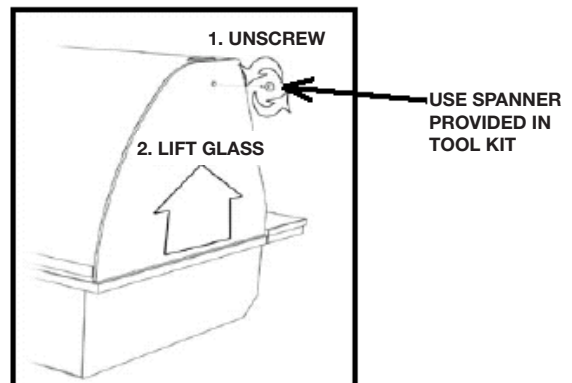

(Example above is an Idesign deli display)

3.0

Self Help Guide For Idesign Heated Drop-In Displays

Problem	Action
<p>Nothing is working</p>	<p>Ensure the power lead is properly plugged into a socket outlet</p> <p>If unsure that socket outlet is live, plug into another appliance to confirm power outlet</p> <p>Check all plugs are securely fitted into EPCM</p> <p>Check fuse in plug top</p> <p>Check MCB for non 13 Amp units</p>
<p>The lights do not work</p>	<p>Make sure power/ main switch is on</p>
<p>The Hotplates/ Bain Marie/ shelves do not work</p>	<p>Check that the other switches/ control knobs are turned on</p> <p>Check that control is switched on, and turn upper heat control fully clock-wise.</p>
<p>The display unit does not keep temperature</p>	<p>Check that the control knobs are turned on</p> <p>Ensure all glass panels are correctly sited</p> <p>Ensure all doors are closed and all controls are on</p> <p>Ensure unit is free from draughts/ air conditioning vents</p>
<p>Neon on gantry is flashing but nothing works</p>	<p>Call your installer for help</p>

If your problem is not listed or persists please contact our service department for help.

IMPORTANT: Please ensure you have your serial number before calling. This will be situated to the right hand side of the gantry controller fascia plate.

Counterline Limited
 Unit 12, Knowsley Business Park
 Merseyside, L34 9HZ
 United Kingdom

Fax: 0151 549 2179
Web: www.counterline.co.uk



Telephone: +44(0)151 548 2211



Email: servicelog@counterline.co.uk