

# Operation & Maintenance Manual

*Idesign Chilled Drop-in Displays*



# IMPORTANT

Counterline Ltd cannot be held responsible for any accidents or injuries sustained through misuse or improper operation / maintenance of its products. Please follow our guidelines set out within this handbook for safe working practice. At the design stage, please ensure that the counter understructure can take the weight of the display(s), and that adequate provision has been made for lifting and positioning the display, to avoid risk of damage or injury.

# SAFETY INFORMATION

It is essential that this Idesign unit is provided with an electrical supply by a qualified electrician and installed by a competent person.

The presence of liquids on the display and risk of spillage must be taken into account in designing the electrical installation around the unit. For additional safety we strongly recommend the fitting of a 30ma trip RCD protection device to the electrical supply. Under no circumstances should electrical cables or points be installed below the evaporator tray area, as water may overflow and cause a hazard.

Idesign display units are heavy. We strongly recommend the use of mechanical lifting equipment when handling the units and positioning them in counters. If no such lifting equipment is available then sufficient personnel must be available to handle each unit without contravening Company or site Health and Safety Policies.

Before commencing any cleaning or maintenance operation the Idesign unit must be isolated from the mains supply by either removing the supply plug from its socket or switching off at the local isolator.

**NB: Switching off using the power switch on the control panel does not fully isolate the unit. These instructions must be implemented in conjunction with your own Company's Health and Safety instructions.**

The following denotes the correct electrical supply required, dependant on unit size:

Chilled display mult-tier			
2/1	2, 3, & 4 tier	2.7 kw	13 amp supply
3/1	2 & 3 tier	2.8 kw	13 amp supply
3/1	4 tier	3.0 kw	13 amp supply
4/1	2, 3 & 4 tier	3.0 kw	13 amp supply

Chilled display wells, decks and delis		
2/1	1.7 kw	13 amp supply
3/1	2.0 kw	13 amp supply
4/1	2.2 kw	13 amp supply
5/1	2.3 kw	13 amp supply
6/1	2.4 kw	13 amp supply

## WARRANTY

All Counterline products are guaranteed against faulty materials and workmanship for 12 months from the date of invoice provided that they have been installed, operated, cleaned and maintained in accordance with these instructions.

This guarantee specifically excludes damage caused by misuse, scratched or broken glass, quartz heat lights, fluorescent lights and electronic starters.



***BEFORE CARRYING OUT ANY MAINTENANCE  
OR CLEANING OPERATIONS SET OUT IN THIS  
MANUAL, PLEASE ENSURE THAT THE  
ELECTRICAL POWER SUPPLY IS ISOLATED  
AND SWITCHED OFF AT THE MAINS.***

# Index

## 1. OPERATION

- 1.0 Switching Your Idesign Chilled Display Unit On
- 1.1 Fault On Switching On
- 1.2 Temperature Control
- 1.3 Defrost Cycles
- 1.4 Display Lighting
- 1.5 Loading With Food
- 1.6 Replacing Fluorescent Lights And Starters
- 1.7 Replacement Of Sneeze Screen Glass
- 1.8 Display Deck Adjustment
- 1.9 Shelving
- 1.10 Shelving (Multi-Tier Display Only)
- 1.11 Multi-Tier Displays
- 1.12 Power Board Plug Positions

## 2. CLEANING

- 2.0 Cleaning Safety Note
- 2.1 Stainless Steel
- 2.2 Cleaning Fluorescent Lights
- 2.3 Cleaning Glass
- 2.4 Cleaning Chilled Display Main Tank
- 2.5 Condensing Unit Finned Coil
- 2.6 Automatic Evaporating Drip Tray
- 2.7 Rear Air Guides (Multi-Tier Units Only)

## 3. TROUBLE-SHOOTING

- 3.0 Ice Build Up On The Coil
- 3.1 Self Help Guide

# OPERATION

These instructions will guide you through the testing, operation, cleaning and maintenance of your Idesign chilled display.

Idesign countertop and drop in food display units are designed for simple operation and will give many years of trouble free service provided that these instructions are adhered to.

**It is essential that you read the instructions carefully and follow all of the cleaning and maintenance instructions. Failure to do so can result in premature failure that will not be covered by warranty.**

## 1.0 Switching Your Chilled Display Unit On

### Idesign Gantry Control Panel

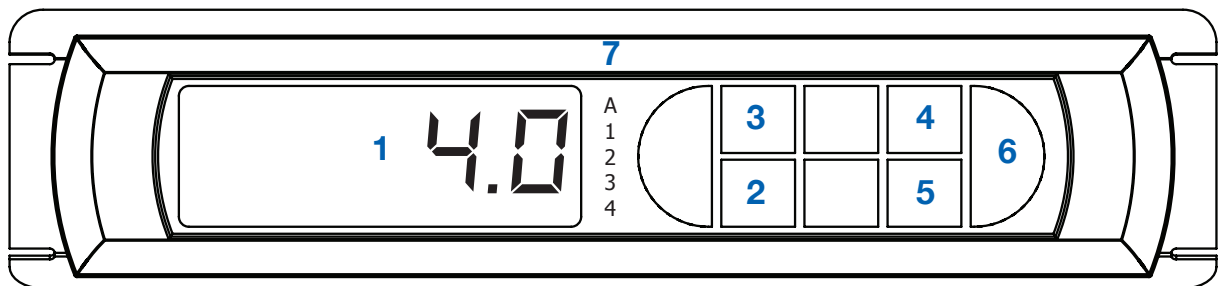

The chilled display unit is factory set to achieve product temperatures between 2-5 deg c

<b>1</b>	Digital temperature display
<b>2</b>	ON/OFF (Green LED) -press for 5 seconds
<b>3</b>	Lights (Yellow LED)- press for 1 second to activate/ deactivate lights
<b>4</b>	(Green LED) -Parameter modification
<b>5</b>	Defrost / Parameter modification (Yellow LED)
<b>6</b>	Parameter settings (Red LED)
<b>7</b>	Engraved Serial Number

The digital controller controls both the circulating air temperature and the defrost cycles. It is pre-set to an average air temperature of 0 degrees Centigrade, which should maintain food below 5 degrees Centigrade in an ambient temperature below 25 degrees Centigrade.

At this stage there is no need to alter this or any other setting of the digital controller.

## 1.1 Fault On Switching On

If after the operation of the main power switch on the control panel it does not illuminate:

1. Check that your Idesign unit has been connected to a mains supply by your installer, and that this supply is live.
2. Isolate the unit and check the supply fuse.
3. Take care to ensure that you replace a fuse with one of the same rating. If you can find no fault call your installer for help.

## 1.2 Temperature Control

In the Idesign system of chilled food display, the food temperature is maintained at or below 5 deg C by a stream of re-circulated cold air.

The air blows across the display deck, coming from grilles or holes on the operators side and returning to the fans via a grille at the customer's side. It is essential that neither of these grilles be obstructed in any way, as the airflow and efficiency of the refrigeration system will be restricted.

The top of the displayed food must also be 50mm lower than the edge of the well or the glass surround if fitted. This system is very effective in a draught free environment with an ambient temperature of no more than 25deg C.

Where ambient temperatures above 25 deg C or draughty conditions exist, the display will not maintain food temperatures at required levels.

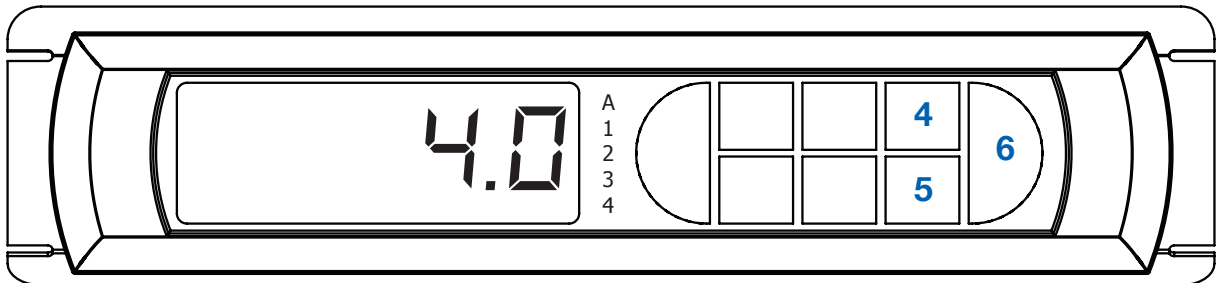

Your digital controller will be pre set at the factory to give a food display temperature of 2/5 deg C in typical operating conditions. Under normal conditions the controller displays the actual temperature of the cold air around the food.

If you need to alter the pre set temperature proceed as follows:

### Gantry digital controller

1. Press Button "6" for 1 second to display the value of the Set Point, flashing;
2. Increase or decrease the value with Button "4" and/or Button "5" until reaching the desired value
3. Press Button "6" again to save the value and display the operating temperature.

It is important that only small adjustments of say 1 or 2 deg C are made to the controller at any one time. The unit should then be allowed to operate for at least one normal working day and food core temperatures monitored before any further adjustments are made.

### 1.3 Defrost Cycles

All chilled Idesign displays have an automatic defrost cycle, which operates every two hours. The air circulation fans continue to run and any ice-build up on the main cooling coil melts.

When this process is taking place and for a short time afterwards the Digital Controller (DIT) will indicate DEF (defrost) instead of a temperature (see below).

The micro processor controller will record where it was in the cycle when the unit was last turned off, so it is possible for the unit to enter a defrost cycle within a few minutes of switching on. This is quite normal.

On a gantry controller, if required, a manual defrost can be started by pressing button “5” for 5 seconds.

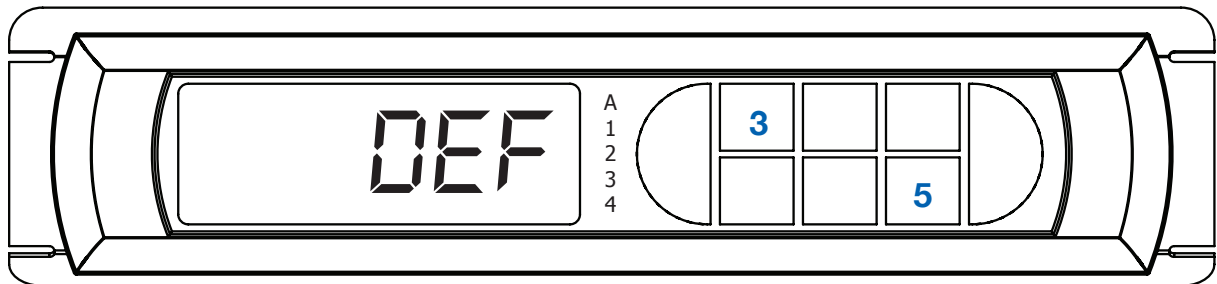

### 1.4 Display Lighting

On a gantry control display lights are switched on by pressing button “3” with the light symbol on it. If the lights do not come on, consult the self help page on section 3 of this manual.

### 1.5 Loading With Food

- Idesign chilled display units are designed to merchandise food that is already at a temperature of 3-5 deg C.
- They are not designed to cool food from ambient temperature.
- It is essential that all food and beverages have therefore been chilled to this temperature before being placed in the display.
- Idesign chilled displays rely on the flow of cooling air from louvres at the front and rear of the display area (and the perforated rear panels of multideck displays).
- These louvres must not be obstructed by placing items too close to them, otherwise the display will not be able to function correctly and food will not be held at a safe temperature.

## 1.6 Replacing Fluorescent Lights & Starters

The lights fitted are standard 25mm slimline fluorescent tubes (colour ref: White 35), and a competent maintenance engineer (who need not be a qualified electrician) can change them.

If a tube is not illuminating properly or flickering it is usually worth changing the starter first to see if this solves the problem.

To remove a starter first isolate the supply then simply grip the top between finger and thumb whilst turning anticlockwise, the starter will then pull out. Replacement is the reverse; gently push the starter into the hole left by the old one whilst turning clockwise at the same time. If this doesn't solve the problem you must replace the tube.

To remove the old tube, firstly isolate the supply and allow it to cool and then turn it through 90 degrees when viewed from its end. It doesn't matter which way you turn it. If you then pull gently away from the fitting it will come clear of its connectors.

To replace it with a new tube first remove the protective packaging and then locate the two connector pins at each end of the tube into the slots in the connector blocks. Gently press the tube into place and then turn through 90 degrees.

In all cases when a fluorescent tube is changed it is recommended that the reflector is cleaned with methylated spirits on a pad of tissue to remove any dirt or grease. This is done most easily after removing the old tube and before inserting the new one. If the light still doesn't work you must call your installer or our service department for help.

## 1.7 Replacement Of Sneeze Screen Glass – If Fitted

Most Idesign units feature curved toughened glass sneeze screens mounted on top of two oval support posts. If this glass becomes chipped or scratched it must be replaced at the earliest possible opportunity as its resistance to breakage by impact or changes in temperature is considerably reduced.

Normally replacement glass can be shipped to you by overnight carrier and the operation to change the glass carried out by any competent maintenance technician or the company that initially supplied your Idesign unit.

**The following operations must only be carried out by persons wearing safety goggles giving all round eye protection:**

integrale<sup>®</sup>

---

1. Isolate the unit from the electrical power.
2. With an assistant to steady the glass, unscrew the two stainless steel allen screws, one in the top of each oval post using the key provided in the fitting kit.
3. Remove the screws, stainless steel ovals and the black plastic mouldings.
4. With an assistant lift both ends of the glass slowly clear of the unit and place it upside down on a flat surface protected by a cloth.
5. Remove the damaged glass from the area and lay the new piece of glass, unwrapped, upside down on the cloth.
6. Again using an assistant and with one of you holding each end of the glass, lower the new glass into position onto the top of the oval posts (ensuring that the lower black plastic moulding is still in place)
7. Ensure that the holes in the glass line up with the threaded holes in the top of the posts.

8. Replace the upper black plastic moulding, stainless steel ovals and screws.
9. Tighten the screws using the key provided in the fitting kit. Do not over tighten as this may cause breakage of the glass.

**P.P.E should be worn when handling glass i.e eye protection and gloves.  
If it is necessary to change the glass on a deli please contact our service department for help.**

## da vinci<sup>®</sup>

---

1. Isolate the unit from the electrical power.
2. Prise off top cover off both gantry posts.
3. With an assistant, unscrew both stainless steel allen screws, one in the top in each oval post, using the allen key provided in the fitting kit.
4. Remove screws and black plastic mouldings.
5. With an assistant lift both ends of the glass slowly clear of the unit and place it upside down on a flat surface protected by a cloth.
6. Remove the damaged glass from the area and lay the new piece of glass, unwrapped, upside down on the cloth.
7. Again using an assistant and with one of you holding each end of the glass, lower the new glass into position onto the top of the oval posts (ensuring that the lower black plastic moulding is still in place)
8. Ensure that the holes in the glass line up with the threaded holes in the top of the posts.
9. Replace the upper black plastic moulding, stainless steel ovals and screws.
10. Tighten the screws using the key provided in the fitting kit. Do not over tighten as this may cause breakage of the glass.

**P.P.E should be worn when handling glass i.e eye protection and gloves.  
If it is necessary to change the glass on a deli please contact our service department for help.**

## manhattan<sup>®</sup>

---

1. Isolate the unit from the electrical power.
2. With an assistant to steady the glass, unscrew the four off pig-nose fixings at either end of the glass using the pig-nose spanner provided in the fixing kit.
3. Remove screws and black plastic mouldings.
4. With an assistant lift both ends of the glass slowly clear of the unit and place it upside down on a flat surface protected by a cloth.
5. Again using an assistant, and with one of you holding each end of the glass, lower the new glass into position and refix with the four-off pig-nose fixings.
6. Tighten the screws using the key provided in the fitting kit. Do not over tighten as this may cause breakage of the glass.

**P.P.E should be worn when handling glass i.e eye protection and gloves.  
If it is necessary to change the glass on a deli please contact our service department for help.**

## 1.8 Display Deck Adjustment

The main display area is adjustable to present the food on either a level or an inclined surface. To adjust the angle:

1. Carefully lift out the display deck sections and set to one side. You will see a number of small clips located in slots in the stainless steel panel below the main air outlet grille.
2. Manoeuvre the clips out of their slots and replace in a higher or lower slot as required.
3. Ensure that there are two clips under each section of display deck and that all clips are on the same horizontal level.
4. Replace the display deck.

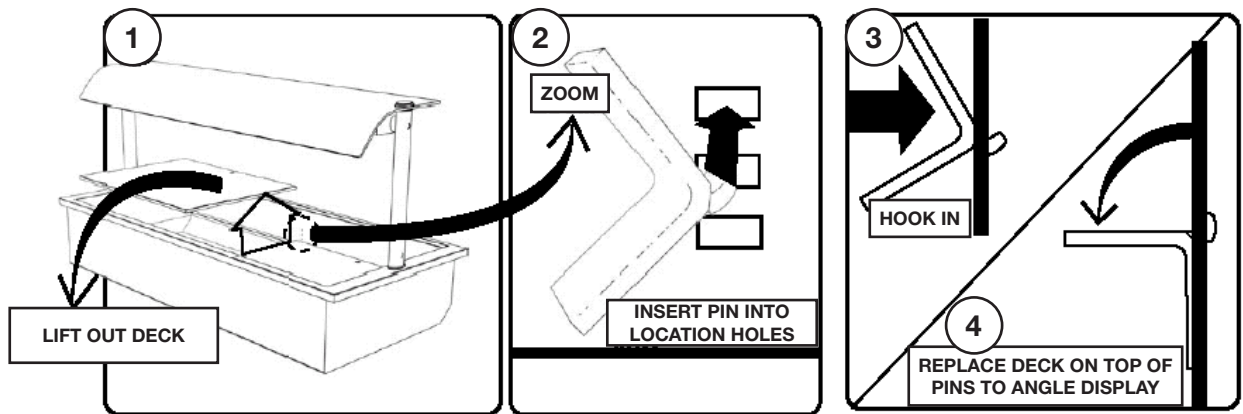

## 1.9 Shelving

The glass shelves if fitted, are located in stainless steel channels and clamped in place by a grub screw from underneath.

The shelves are designed to be positioned so that the front edges are in a vertical line above one another, but positioning in the deli units is not critical and this may be varied to suit individual applications. High capacity air curtain shelves just sit on the support brackets and can be just lifted out.

Should it be necessary to remove or adjust the shelf position the grub screws can be loosened with the allen key provided in the service kit.

The screws should only be tightened gently as too much pressure can break the glass.



## 1.10 Shelving (Multi-Tier Display Only)

Multi tier shelving is supported on stainless steel brackets that are hooked on the back of the unit. To remove the glass, carefully lift each piece of glass off the support bracket and set aside. You can now adjust the height of the shelves simply by inserting the brackets at the rear of the unit in alternative locating holes.

**Ensure that before replacing the glass shelves the brackets are firmly secured and locked in position.**

**It is essential that safety glasses are worn when removing any pieces of glass.**

## 1.11 Multi-tier Displays

This system offers chilled food display at countertop level and also on two, three or four shelves above. The food temperature is maintained at or below 5 deg C by a stream of re-circulated cold air. The air normally blows down from a slot at the top front edge of the display, returning to the fans and cooling coil through a horizontal grille at the customer's side of the countertop. Some air is directed across each of the shelves from small holes at the back of each shelf.

Idesign multi-tier displays are available with and without doors for rear loading, usually the doors will be specified on a display built into a front counter, solid fixed rear panels are used where display units are built up against walls.

If doors are fitted they are held in the closed position by magnets and will stay open at an angle of about 120 degrees.

To maintain the temperature in the display you should only open one door at a time for the shortest period possible.

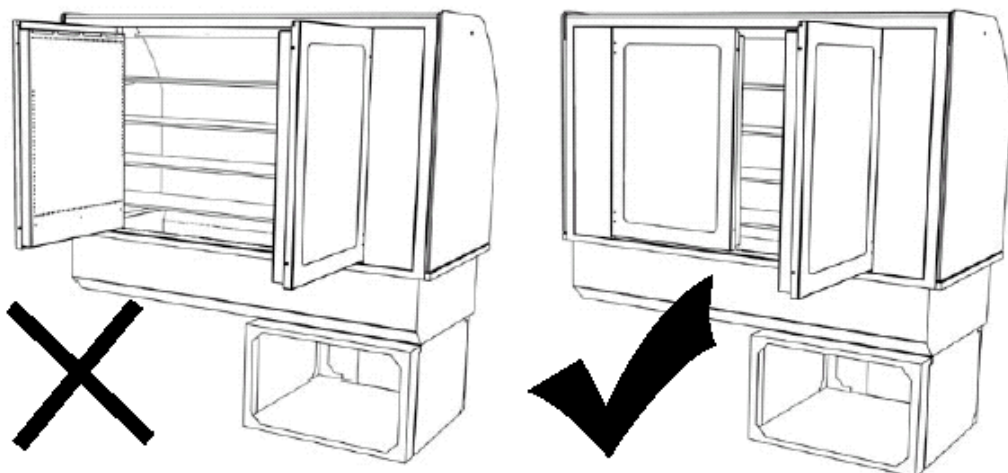

**ONLY OPEN ONE  
DOOR AT A TIME**

**1.12 Power Board Plug Positions**

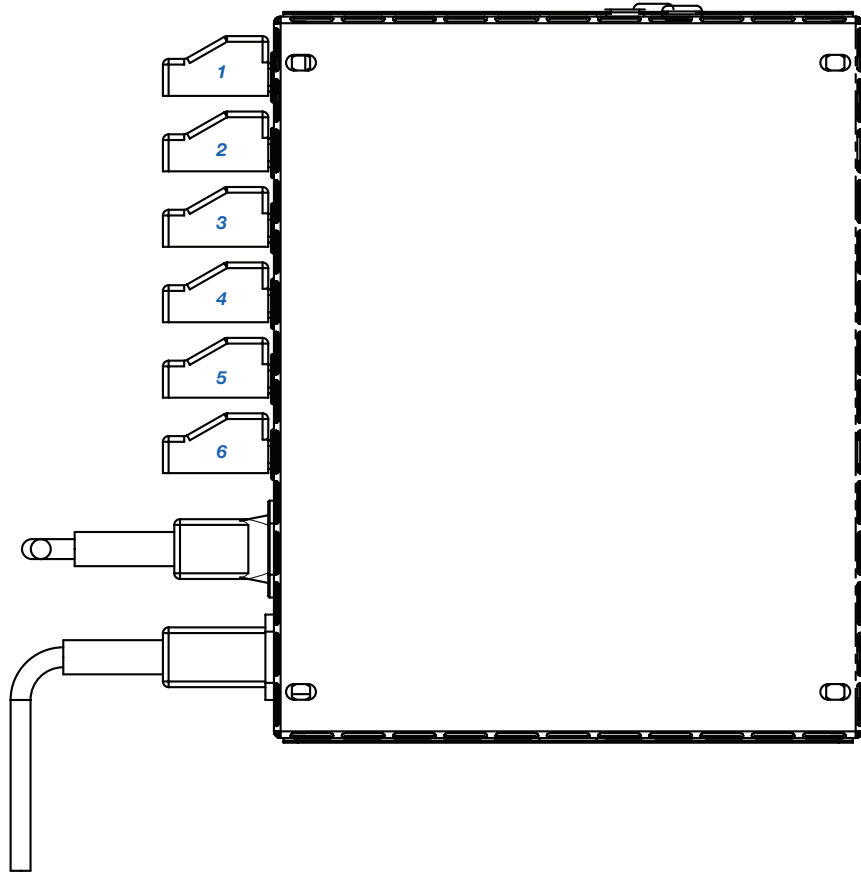
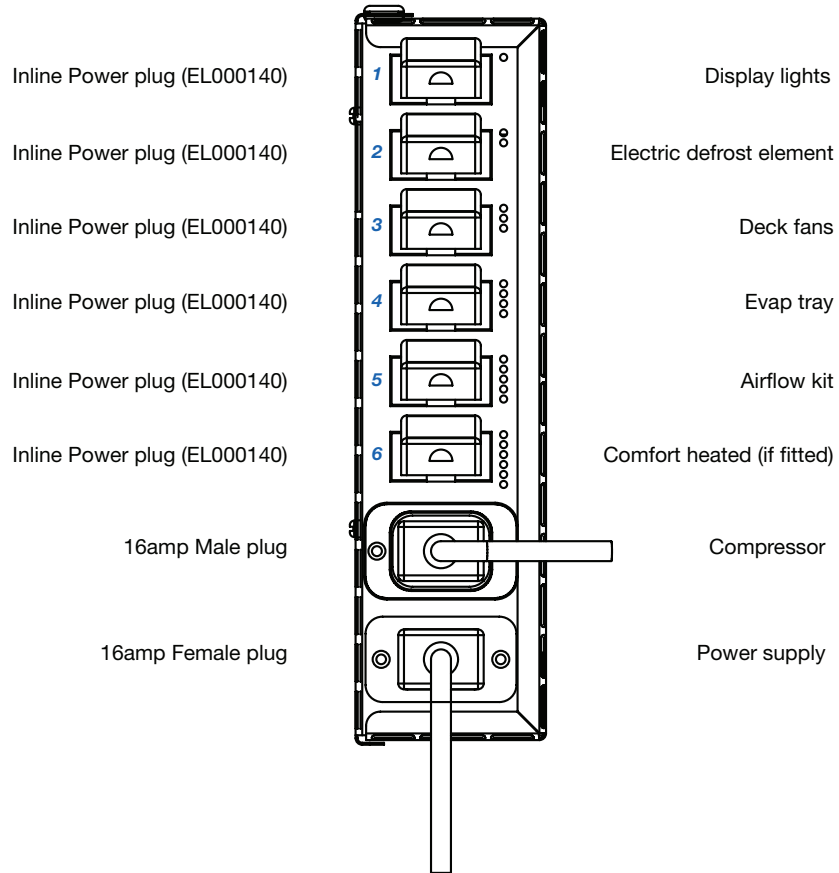

# CLEANING

---

## 2.0 Cleaning Safety Note

Before commencing any cleaning operation the Idesign unit must be isolated from the mains supply by either removing the supply plug from its socket or switching off at the local isolator.

**NB: Switching off using the power switch on the control panel does not fully isolate the unit. Under no circumstances must a pressure washer or hosepipe be used in the vicinity of this unit.**

## 2.1 Stainless Steel

Stainless steel should be cleaned daily using a suitable proprietary stainless steel polish applied in accordance with the manufacturer's instructions.

A list of recommended cleaning products is available from our service department.

**Do not use harsh abrasives or cleaning pads such as Scotchbrite**

## 2.2 Cleaning Fluorescent Lights

The light output from fluorescent display lights will be maintained if they are carefully cleaned monthly when cold using a pad of tissue slightly moistened with methylated spirits. Nothing else should be used.

At the same time the reflectors should be wiped clean with a similar pad.

**Replacement fluorescent lights are not covered by warranty.**

## 2.3 Cleaning Glass

Glass shelves and sneeze screens should be cleaned daily or as required using a proprietary glass cleaner and clean cloth. Care should be taken to select a cleaner with minimum odour to avoid food tainting.

Your unit may be provided with the optional full height curved glass sneeze screen and fully glazed ends. The ends are located into black plastic guide channels and fixed in place with special flush stainless steel screws. Normally the ends can be cleaned in situ, but occasionally they should be removed to allow for more thorough cleaning. The fixing screws can be removed and replaced with the special tool provided in the fixing kit. When removing them take note of the position of the spacing washers and replace them in exactly the same order. When replaced, the fixing screws should not be over tightened or the glass may be damaged.

The front glass is supported along its lower edge in a full-length hinge, so that the glass can be opened forwards towards the customer side for access to clean its inner face. To open the glass, stand in front of the counter, take hold of both ends of the glass at the top and pull it upwards and towards you.

The glass has a restraining device built into its hinge. This is just a restraining device and is not designed to support the full weight of the glass. When cleaning ensure that you hold the glass with one hand and refrain from putting any additional weight on the glass or hinge.

After cleaning, the glass is returned to its normal position.

### TILTING THE GLASS FORWARD

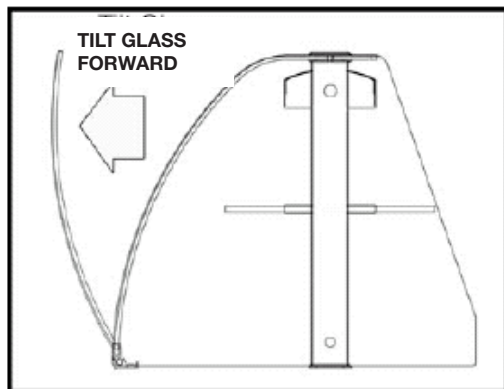

### REMOVING THE GLASS ENDS

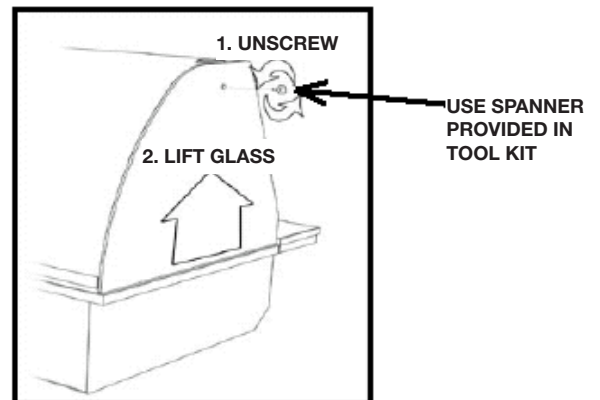

(Example above is an Integrale Chilled Display Deli)

## 2.4 Cleaning Chilled Display Main Tank

This operation must be carried out monthly with the display disconnected from the electrical supply.

If your display is fitted with a full height sneeze screen, you will need to remove it before attempting to carry out this cleaning operation.

Lift out the main display deck sections and set aside. This will expose two separate metal plates, one of which supports the air circulation fans and the second is a baffle plate guiding the air through the main cooling coil. These plates are secured by finger-tightened screws, which are removed without tools.

Once the screws have been removed the fan mounting plate can be lifted out taking care not to strain the wiring, the coil cover plate can then be removed and the main cooling coil exposed. Remove any food debris using a vacuum cleaner followed by a cloth and detergent.

Wipe the fan blades using a damp cloth and detergent. Finally spray the interior of the tank and the finned cooling coil generously with a sanitising solution such as Dettol. Avoid using excess water if your unit is not connected to a plumbed drain, as this may cause the automatic evaporating drip tray to over flow. Re-assembly is the reverse of the above.

When cleaning the unit you must inspect the main cooling coil. You should find the coil covered with a thin layer of frost or ice. Anything up to about 2mm thick is quite normal but anything in excess of this seriously impairs its efficiency.

If there is a build up of ice refer to section 3.1.

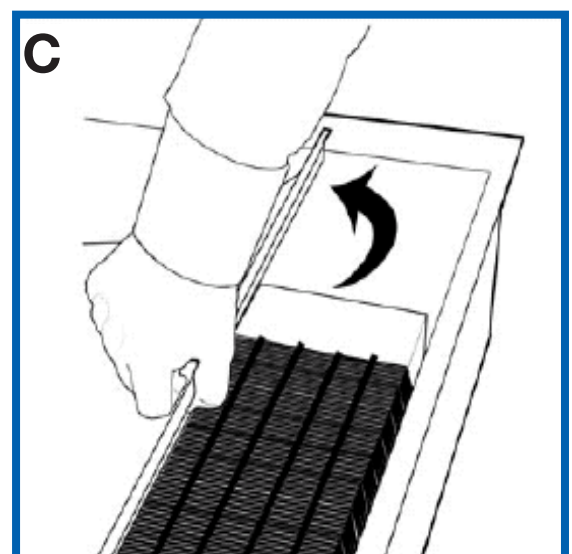
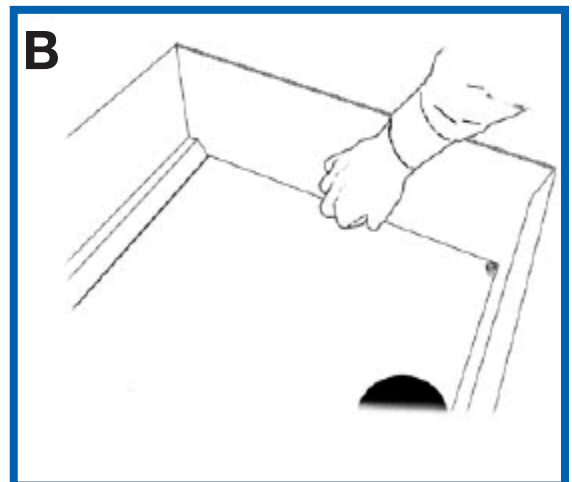
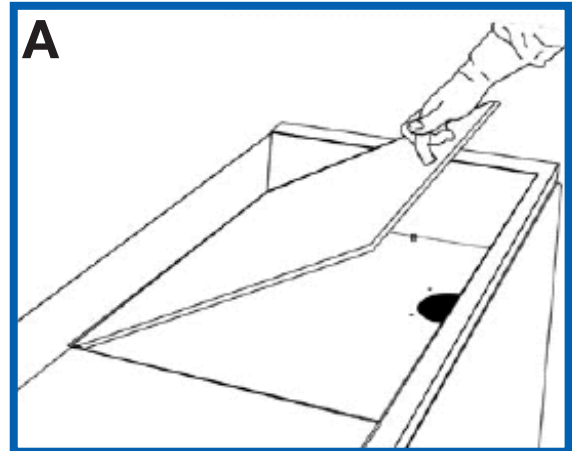

**2.5 Condensing Unit Finned Coil**

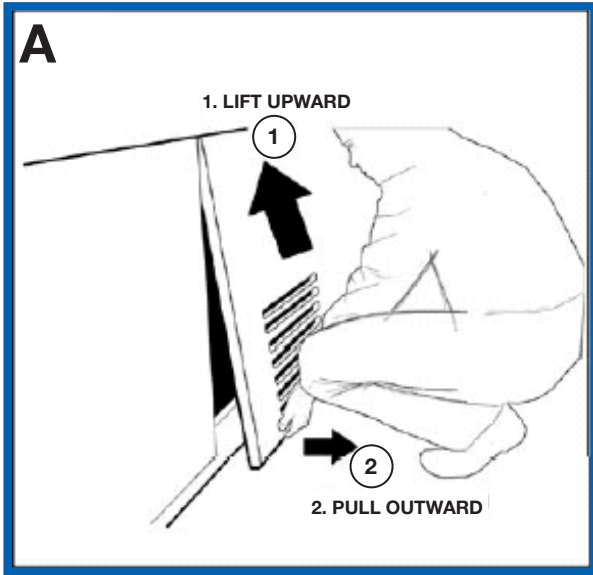

**This must be cleaned monthly**

Located under the display is the condensing unit. This can be accessed for cleaning by either removing a grille in the fascia panelling of the counter or by removing the panel itself.

The exact method of access will depend on the counter construction. If you cannot work out how to get access you must contact your installer for assistance.

The size of the condensing unit will vary with the type of display but in general it is about 400 mm square and comprises a grid of very fine black metal fins. These fins become choked with dust and airborne particles. They should be cleaned using a soft brush to loosen the dust and a vacuum cleaner to remove it. The fins are very delicate and considerable care is required.

If you are in any doubt as to your ability to carry out this operation safely call your installer and arrange for them to do it for you. If this operation is neglected or carried out without sufficient care, a new condensing unit may be required, and the cost of its replacement will not be covered by warranty.

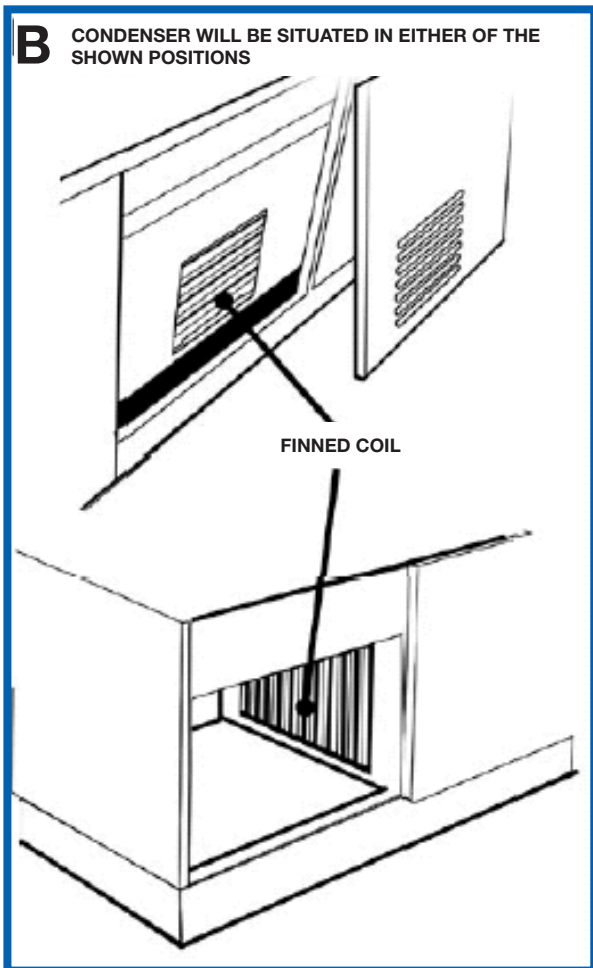

## 2.6 Automatic Evaporating Drip Tray

**This must be cleaned every three months.**

- This must be cleaned every three months.
- The drip tray operates at all times, even when the power switch is turned off.
- To clean the drip tray the supply to the Vision unit must be totally isolated from the main supply by turning off the counter main switch.
- Allow the drip tray to cool down before touching it.
- The automatic evaporating drip tray is located under the right hand end of the display when viewed from the rear.
- It can be accessed for cleaning by either removing a grille in the rear panelling of the counter or by removing the panel itself. On a drop-in it is located in the cradle.
- The drip tray is a stainless steel tank about 500mm long and 100mm high, resting in it is a heating element, which is connected via a short lead to a plug.
- Remove the plug from its socket and carefully lift out the drip tray and element together. There is likely to be some water in the tray, which you should discard.
- Inside the tray and on the element will be a build up of deposits similar to the scale inside a kettle. As much of this as possible must be removed by a combination of scraping, Scotchbrite and kettle cleaner. It is not necessary to achieve perfection, just remove the majority.
- Be careful not to distort the element when cleaning it.

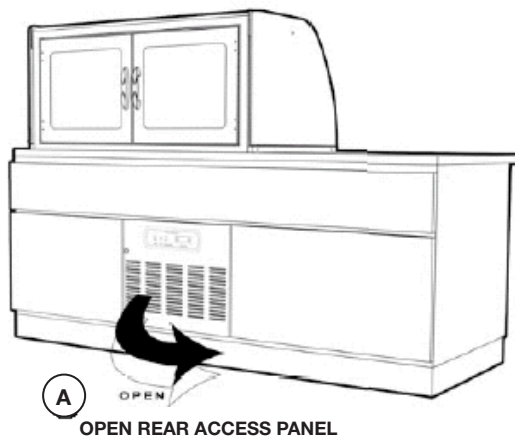

**WARNING**

**TAKE CARE WHEN REMOVING THE EVAP-TRAY. ENSURE THE UNIT IS SWITCHED OFF AND THE EVAP-TRAY HAS COOLED SUFFICIENTLY**

**ONCE THE REAR ACCESS PANEL HAS BEEN REMOVED YOU WILL SEE THE FOLLOWING**

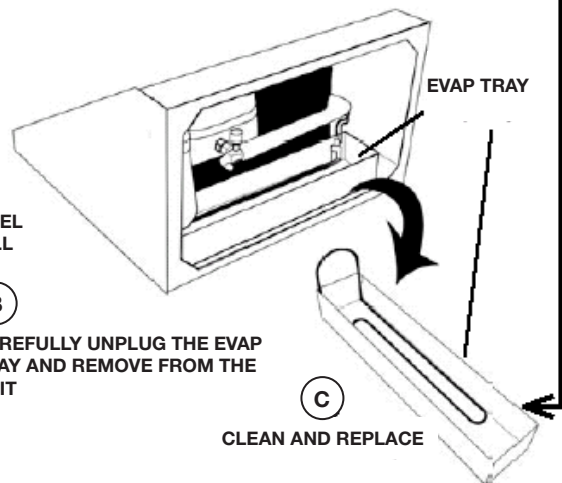

**B CAREFULLY UNPLUG THE EVAP TRAY AND REMOVE FROM THE UNIT**

**C CLEAN AND REPLACE**

## 2.7 Rear Air Guides (Multi-Tier Units Only)

Idesign multi-tier displays use vertical perforated panels behind the shelves to guide the chilled air around the unit. In fixed back units they are polished stainless steel, in units with rear doors they are clear plastic.

The air guides are located into slots in the rear doors or rear framework.

In fixed back units it is necessary to first remove the glass shelves (**see instructions 1.9**) to gain access to the air guides. In units with rear doors access is obtained by simply opening the doors.

At weekly intervals these should be removed by lifting upwards and away from the doors or framework, and then wiped on both sides with a soft damp cloth.

**Under no circumstances should any abrasive be used, as it will scratch the surface of the plastic or stainless steel.**

To reassemble, locate the projecting tongues on the guides into the slots in the doors or framework and then gently ease the guides downwards into position.

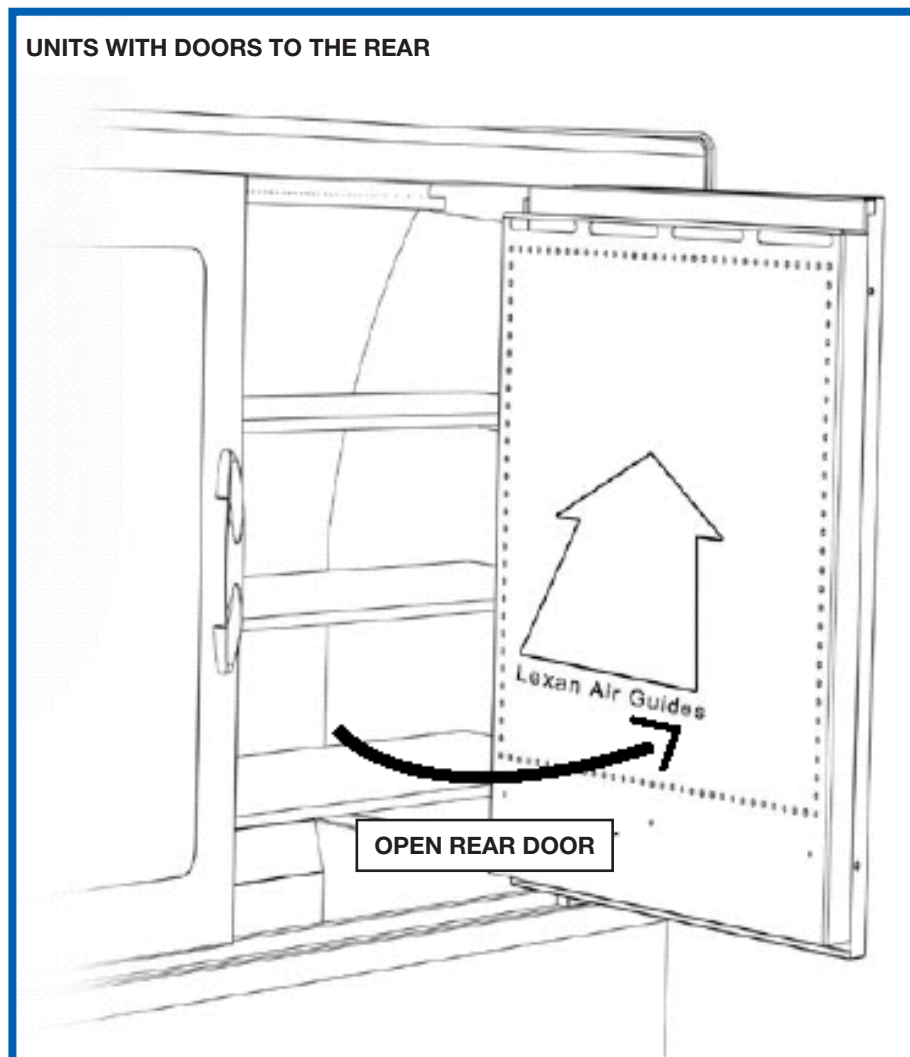

# TROUBLE-SHOOTING

---

## 3.0 Ice Build Up On The Coil

In conditions of high humidity it is possible for ice to accumulate on the coil, and not be fully cleared by the defrost system. This problem is usually only likely to occur on units operating 24hours a day in conditions of high humidity. The result will be a failure to maintain temperature, as airflow through the coil is restricted.

If during cleaning an excessive build up of ice is observed, turn the unit off overnight with the main deck and airflow baffle plates removed.

**Isolate the display unit completely from the mains electricity supply. Turning off the power switch on the display is not sufficient.**

**If the build up was very heavy and the unit is fitted with an automatic evaporating drip tray it will be necessary to guide the water resulting from the melting of the ice into a bucket rather than the evaporating drip tray otherwise it will overflow.**

**Remove the evaporator drip tray and locate a funnel or bucket under the plastic waste pipe located above it. See cleaning instructions for removal of the drip tray.**

When all the ice has melted re-assemble the tank and deck components, re-fit the evaporator drip tray, then switch the power back on and check the operation of the unit.

If you are in any doubts of your ability to carry out the above procedure please contact our service department for assistance.

Please note that a visit by a service engineer to clear the coil of ice will not be covered by warranty unless it is established that it was caused by a component failure.

If the build up repeats itself try turning the unit off every night.

**If this does not solve the problem call our service department on 0151 548 2211 to check the operation of the defrost system.**

**3.1 Self Help Guide For Chilled Display Drop-ins**

Problem	Action
<p><b>Nothing is working</b></p>	<p>Ensure the power lead is properly plugged into a socket outlet</p> <p>If unsure that socket outlet is live, plug in another appliance to confirm power is available</p> <p>Check fuse in plug top and on control panel</p> <p>Make sure power/ main switch is on</p>
<p><b>Only the lights are working</b></p>	<p>Check that the other switches/ control knobs are turned on</p> <p>Check that the electronic temperature controller is illuminated</p>
<p><b>Condensing unit has gone off</b></p>	<p>It will switch off at a regular intervals as governed by the controller and come back on automatically</p>
<p><b>The controller displays 'DEF'</b></p>	<p>To prevent the display icing up, an automatic defrost cycle is pre-programmed into the controller. DEF will appear every 2 hours during defrost and recovery. This is to maintain the efficiency of the display.</p>
<p><b>Steam is seen from louvered door</b></p>	<p>The automatic condensate waste tray is operating normally.</p>
<p><b>The temperature of the produce is too high</b></p>	<p>Check setting of temperature controller</p> <p>Ensure airways are not blocked</p> <p>Ensure fans are operating</p> <p>Ensure the doors are closed</p> <p>Move display case from draughts/ air conditioning vents</p> <p>The evaporator coil is iced up</p> <p>The condensing unit coil is blocked</p>

If your problem is not listed or persists please contact our service department for help.

**IMPORTANT:** Please ensure you have your serial number before calling. This can be located in the center of the gantry controller fascia plate.

Counterline Limited  
 Unit 12, Knowsley Business Park  
 Merseyside, L34 9HZ  
 United Kingdom

**Fax:** 0151 549 2179  
**Web:** www.counterline.co.uk



**Telephone:** +44(0)151 548 2211



**Email:** servicelog@counterline.co.uk